



Pedestrian Barriers MAGSTOP

Pivot MPP 122

Technical Data:	Typ	MPP 122
Voltage	VAC	115–240
Frequency	Hz	50–60
Current nom.	mA	200
Current max.	mA	850
Duty Cycle	%	100
Protection	IP	32/44
Length	mm	1300
Width	mm	260
Height	mm	1035
Weight	kg	60

Product Description

The Pedestrian Barrier Pivot series type MPP (Magnetic Pedestrian Pivot) is designed to control pedestrians entering or exiting restricted areas, usually under surveillance, in low security situations.

Personal surveillance is therefore recommended as the barrier can be breached. The barrier consists of a rotating center, at 3 x 120 degrees, providing single access via a card reader or external control panel through steps of 1 x 120 degrees.

The operation of the barrier allows for controlled two directional pedestrian flow and is capable of blocking in either direction, or free rotation in either direction.

This model can be used in two directional control applications with a high usage of pedestrian traffic such as: railway platforms, passenger terminals and sport stadiums.

Typical Fields of Applications:

- Train stations
- Airports
- Sports stadiums
- Museums
- Company entries
- Swimming pools
- Public convenience

Housing

The construction consists of a center housing connected to two end modules. The center housing has a dust / waterproof hinged locked cover providing optimum access to the controllers and electro-mechanical drive mechanism.

Various optional access control devices (such as card readers, finger print readers etc) can be accommodated on a fascia panel at the ends of the barrier each.

Optional: Removable fascia panels either made of stainless steel or "Makrolon" (a sort of synthetic material) is available on demand.

The pivot barrier design is also available in two constructions.

Version 1

Standard type for indoor installations
Polished steel plate 430 stainless steel with protection class IP 32

Version 2

For outdoor installations. (No roofing required.)
Polished steel plate 316L stainless steel with protection class IP 44

Motor Drive

Our new developed and patented Magnetic High Torque Motor MHTM with sensor technique is the focus of the drive unit. The MHTM motor allows a direct drive of the rotating center without additional gear.

In connection with the new universal MBC controller we can provide functional features that are very useful and expedient for our customers. The motor offers a near noiseless operation, smallest dynamic impact forces, lowest abrasion and highest positioning accuracy of the rotating arms.

Performance and speed of the motor is set by a response curve, i. e. the motor will try to meet the set position and speed regardless the user stopping the turnstile arm during rotation. This provides an optimized running behavior. Thus accelerating or over spinning of the home position is almost eliminated.

In the case of the motor power being insufficient to prevent someone from an illegal entry or a vandalism forced rotation in the opposite direction, then activation of a secondary coupling will prevent fraudulent use. Under normal operation the secondary coupling is inactive.

The retention force of the secondary coupling is in the range of 700 – 800 N applied at the ends of the turnstile arms. The second-

dary coupling is designed to slip in excess of forces greater than 800 N in order to prevent the mechanical damage to the drive mechanism.

Under these circumstances the system will reset and the rotating center will find home position.

The MHTM motor operates under constant power in the home position; therefore the heat dissipated prevents any condensation and prolongs the life of the motor.

Option

Optionally the MPP Pedestrian Pivot can be fitted with a patented Drop Arm.

It is designed for the case of emergency, e.g. fire alarm, accident or in the event of power failure to allow free passage. Hence the turnstile arm turns down after power fails or is manually switched off.

When power resumes the turnstile arm returns to its correct position and the rotating center resets and returns to the operating home position.

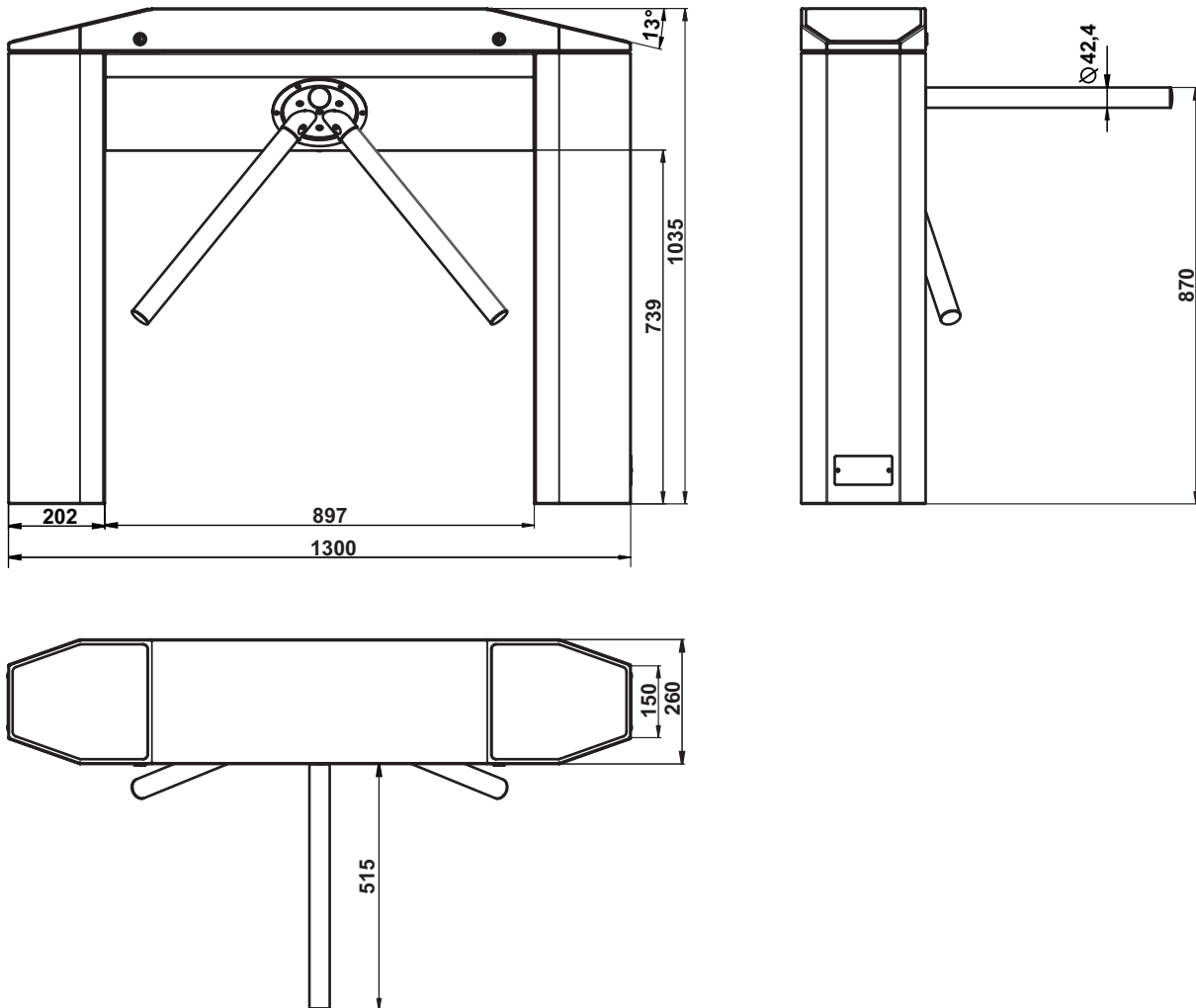

Dimensional Diagram